

ALBERT MODELL

Meticulously crafted miniature models for demanding collectors

Photo : Raphaël Gulli



Tapps / Tanpps freight wagons

Novelty 2024
HO scale

Novelty 2024

Tapps / Tanpps freight wagons

Albert Modell is delighted to present its first model for the French market. This is an original HO scale model, never before reproduced by an industrial manufacturer. The model belongs to the family of Tapps and Tanpps type wagons, also known as the T90 series, including the well-known "Transengrais" wagons.

These wagons were built from 1983 onwards by various manufacturers such as CFMF, Fauvet-Girel, ANF, and AFR, in several versions. The study of these wagons takes into account all the variants from eras IV, V and VI (SNCF, CTC, France Wagons, Ermewa).

Our goal is to produce a wagon with a very high level of detail that will please enthusiasts, while keeping the price reasonable. We will offer all versions, including those intended for sugar transport, respecting their specific differences. The wagons will be mounted on either welded or molded Y25 bogies, depending on the model. Two different registrations will be available for each variant.

These wagons will include many detailed parts, such as the CG on the sides, the roof control rods, and all the control chains. Expected by late 2024 / early 2025, below you will find the first series of wagons which, we are sure, will delight wagon enthusiasts.

Expected release date: end 2024 / beginning 2025 | Recommended retail price: 54€



Photo: Patrick Sambourg



Photo: Frédéric Poupelain

Nouveauté 2024

Wagons de marchandises Tapps / Tanpps

Albert Modell est ravi de vous présenter son premier modèle destiné au marché français. Il s'agit d'un modèle inédit à l'échelle HO, jamais reproduit par un industriel jusqu'à présent. Ce modèle appartient à la famille des wagons de type Tapps et Tanpps, désignés sous le code T90, comprenant notamment les wagons « Transengrais » bien connus.

Ces wagons ont été construits à partir de 1983 par divers constructeurs tels que CFMF, Fauvet-Girel, ANF et AFR, en plusieurs exemplaires. L'étude de ces wagons prend en compte toutes les variantes existantes des époques IV, V et VI (SNCF, CTC, France Wagons, Ermewa).

Notre objectif est de produire un wagon avec un très

haut niveau de détails qui satisfera les passionnés, tout en maintenant un prix abordable. Nous proposerons toutes les versions, y compris celles destinées au transport de sucre, en respectant les différences spécifiques. Les wagons seront montés sur des bogies Y25 soudés ou moulés, selon les modèles. Deux immatriculations différentes seront disponibles pour chaque variante.

Ces wagons incluront de nombreuses pièces de détail, telles que la CG sur les flancs, les tringles de commande du toit, ainsi que l'ensemble des chaînes de commande. Prévu pour fin 2024 / début 2025, vous trouverez ci-dessous les premières séries de wagons qui, nous en sommes sûrs, raviront les passionnés de wagons.

Date de sortie prévue : fin 2024 / début 2025 | Prix de vente conseillé : 54€



Photo : Patrick Sambourg



Photo : Patrick Sambourg

6 versions will be produced / 6 versions seront produites

T84

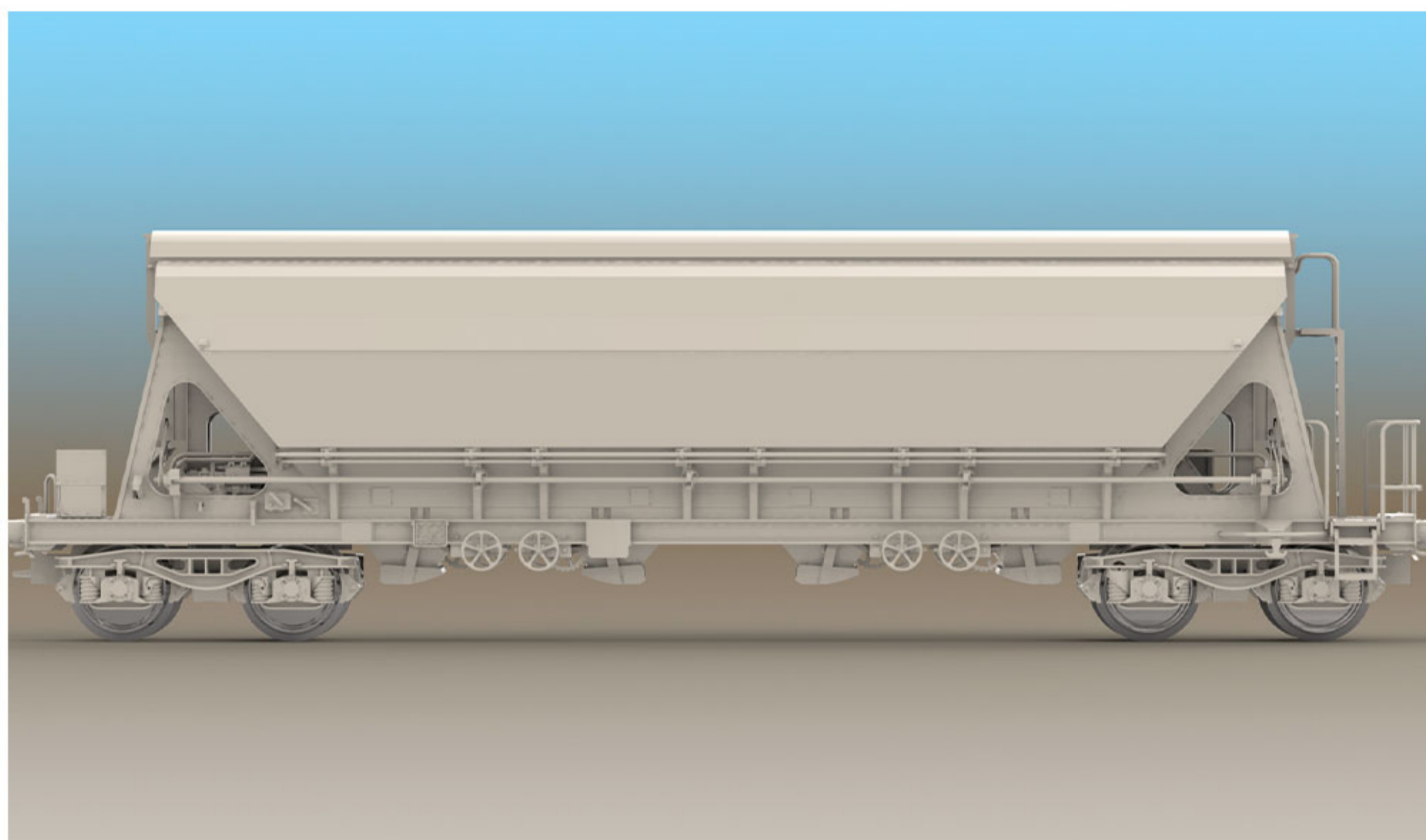

Welded Y25 bogies / Bogies Y25 soudés

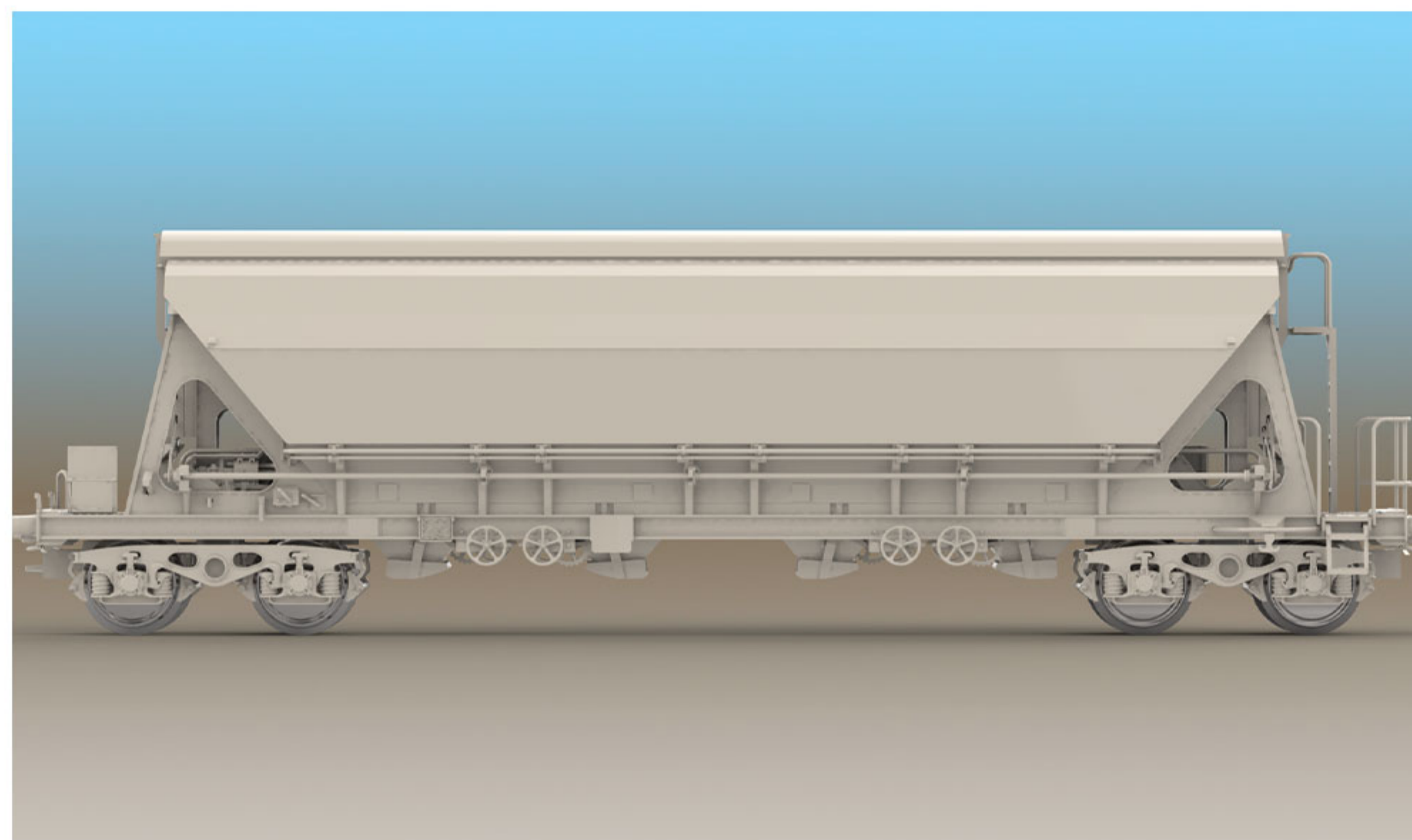

Cast Y25 bogies / Bogies Y25 moulés

T90

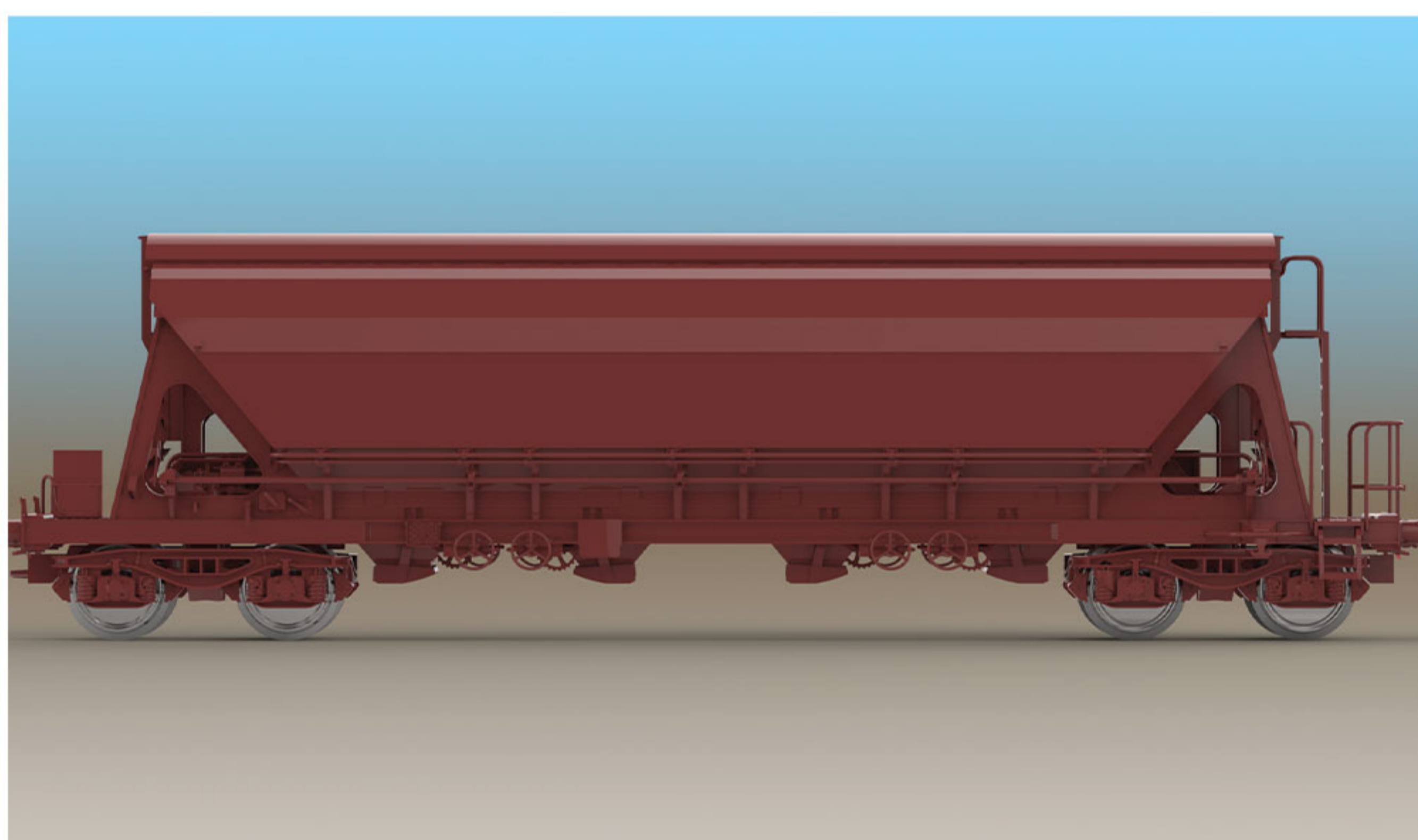

Welded Y25 bogies / Bogies Y25 soudés

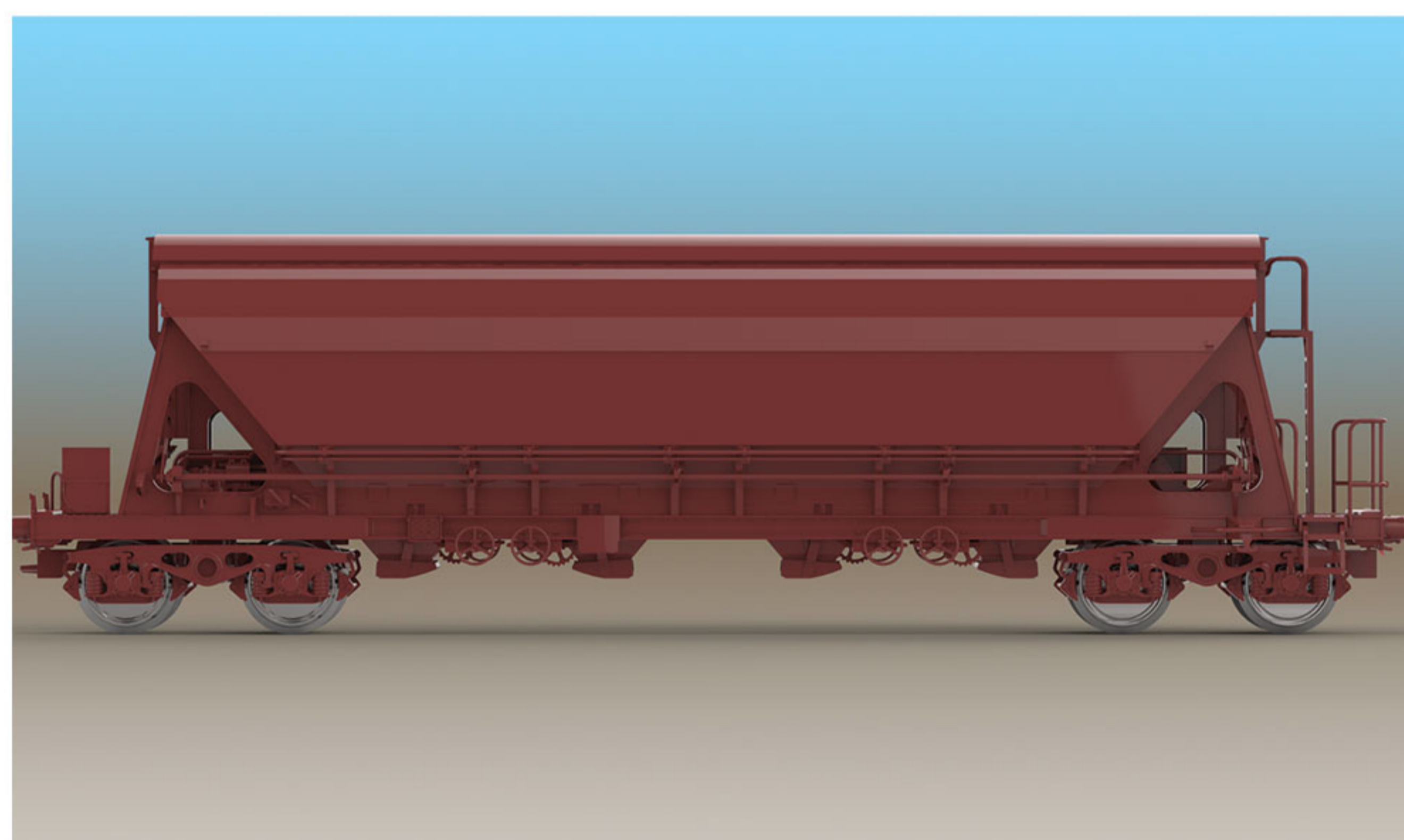

Cast Y25 bogies / Bogies Y25 moulés

"Sucre"

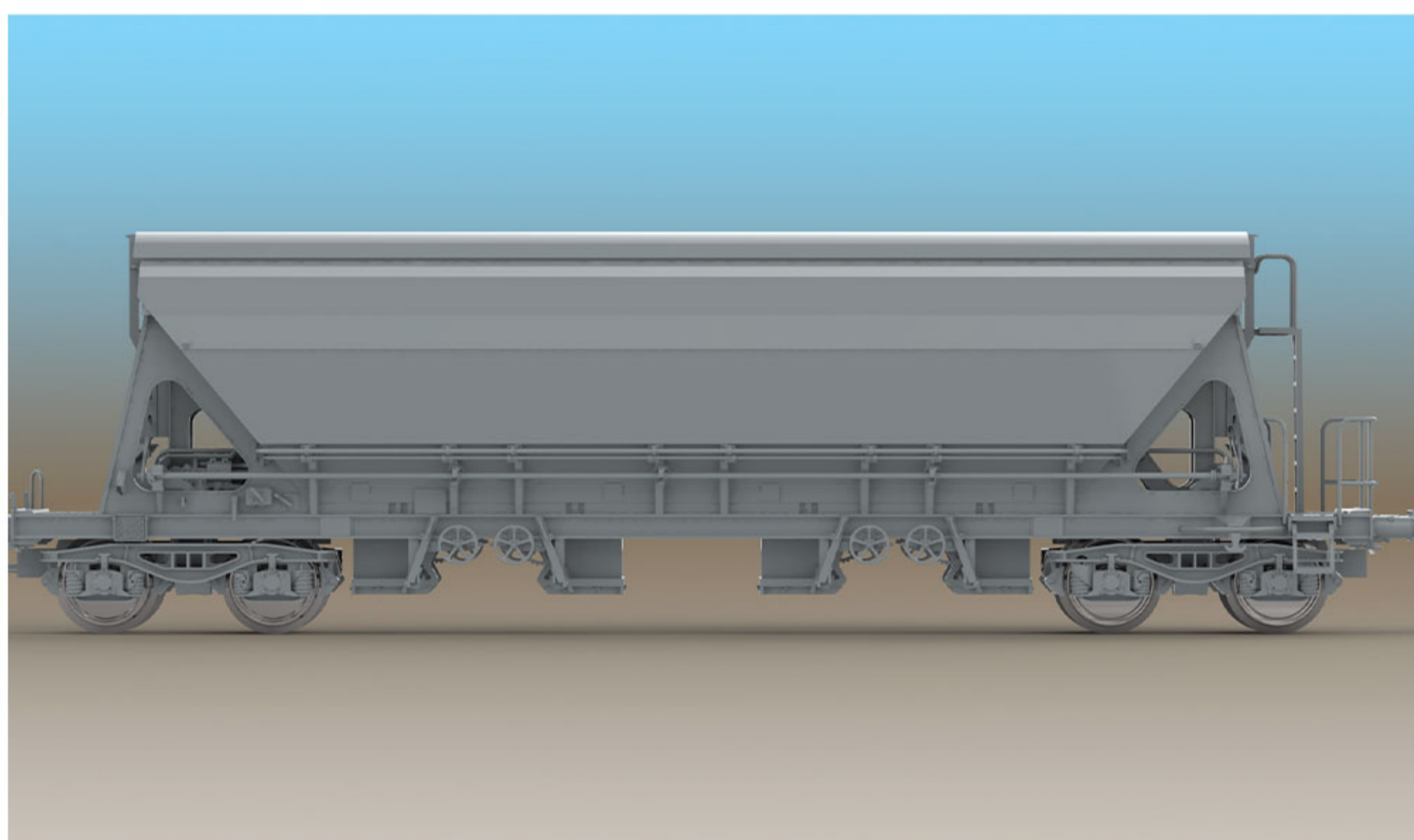

Welded Y25 bogies / Bogies Y25 soudés

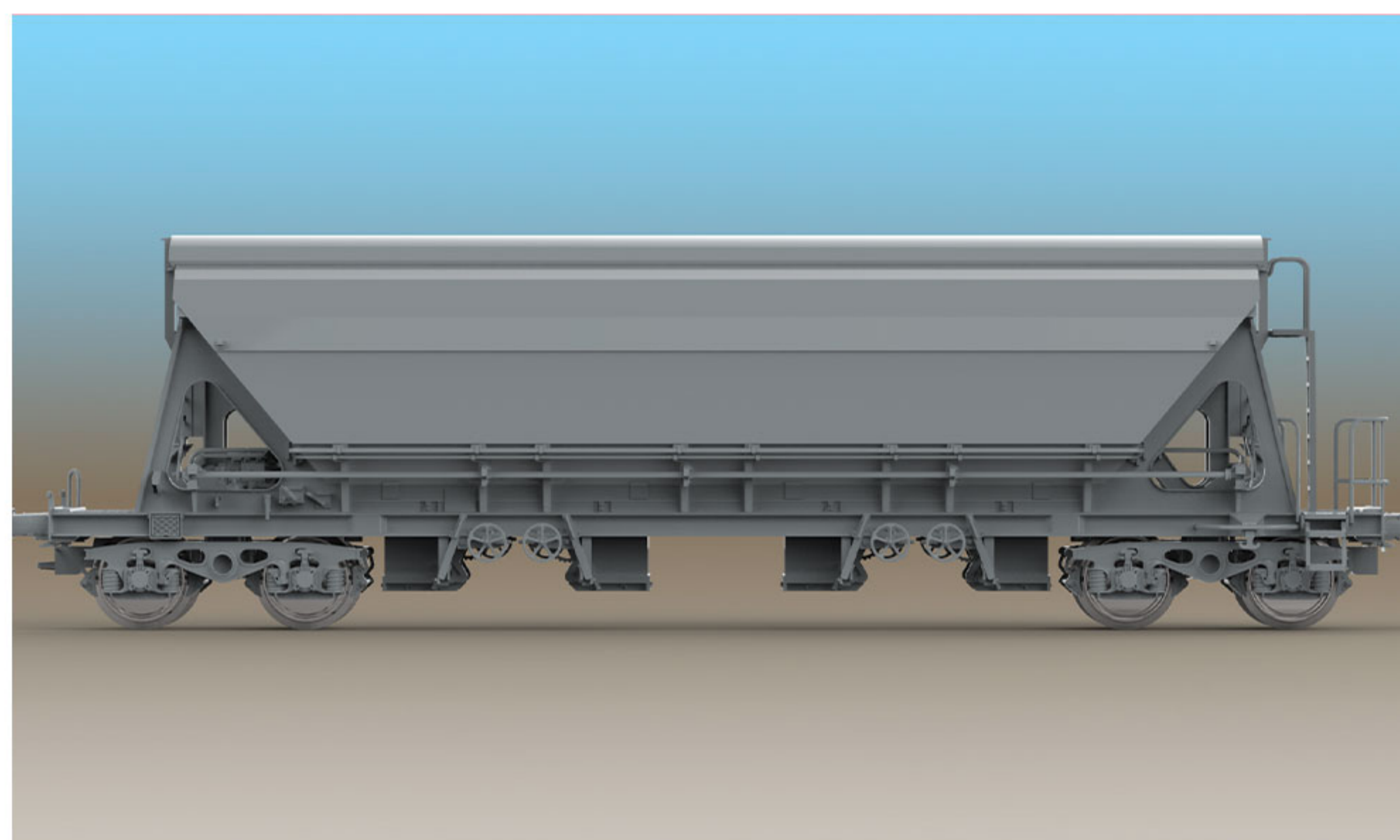

Cast Y25 bogies / Bogies Y25 moulés

The model will consist of about 160 parts

/ Le modèle sera composé d'environ 160 pièces

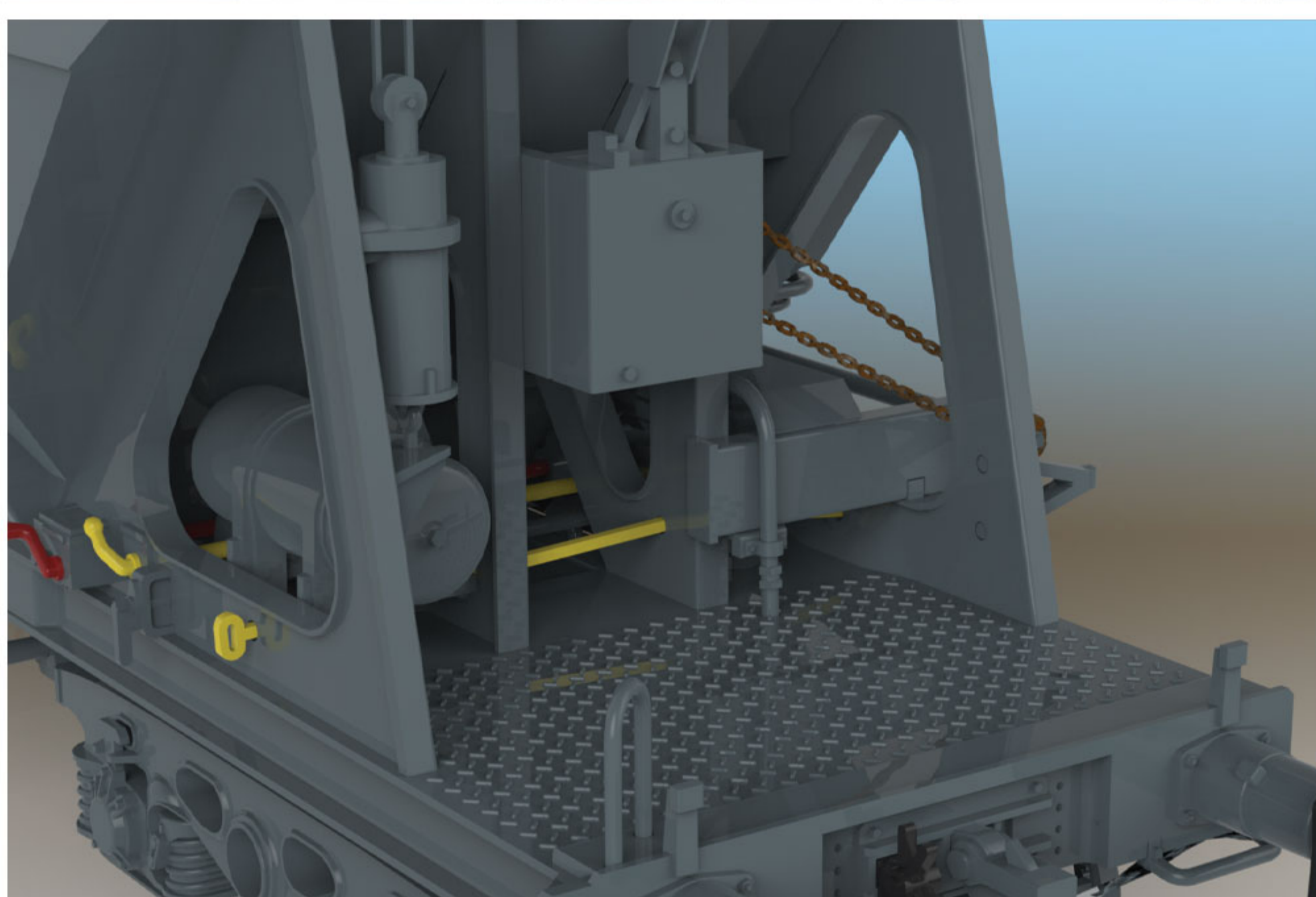
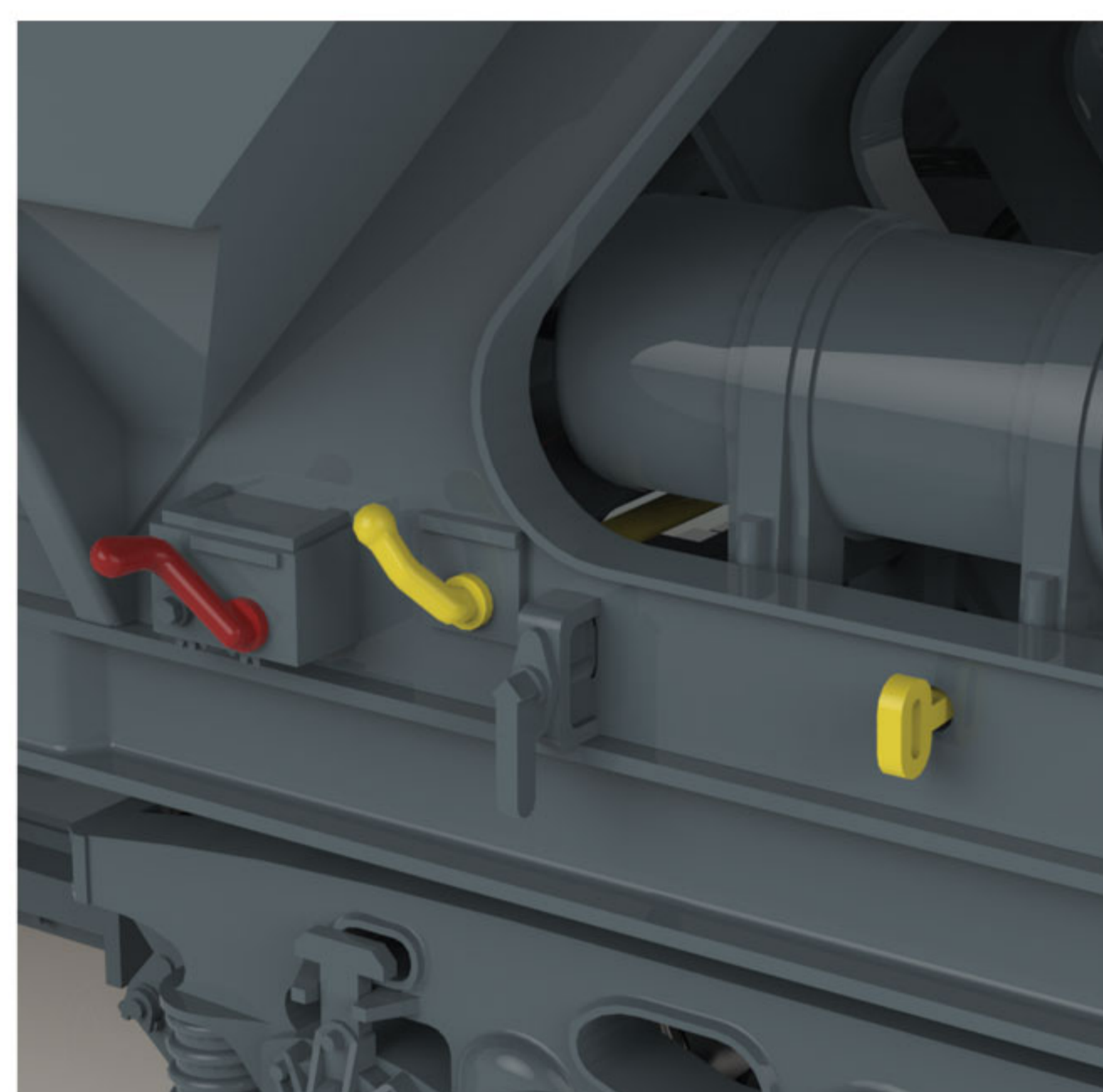
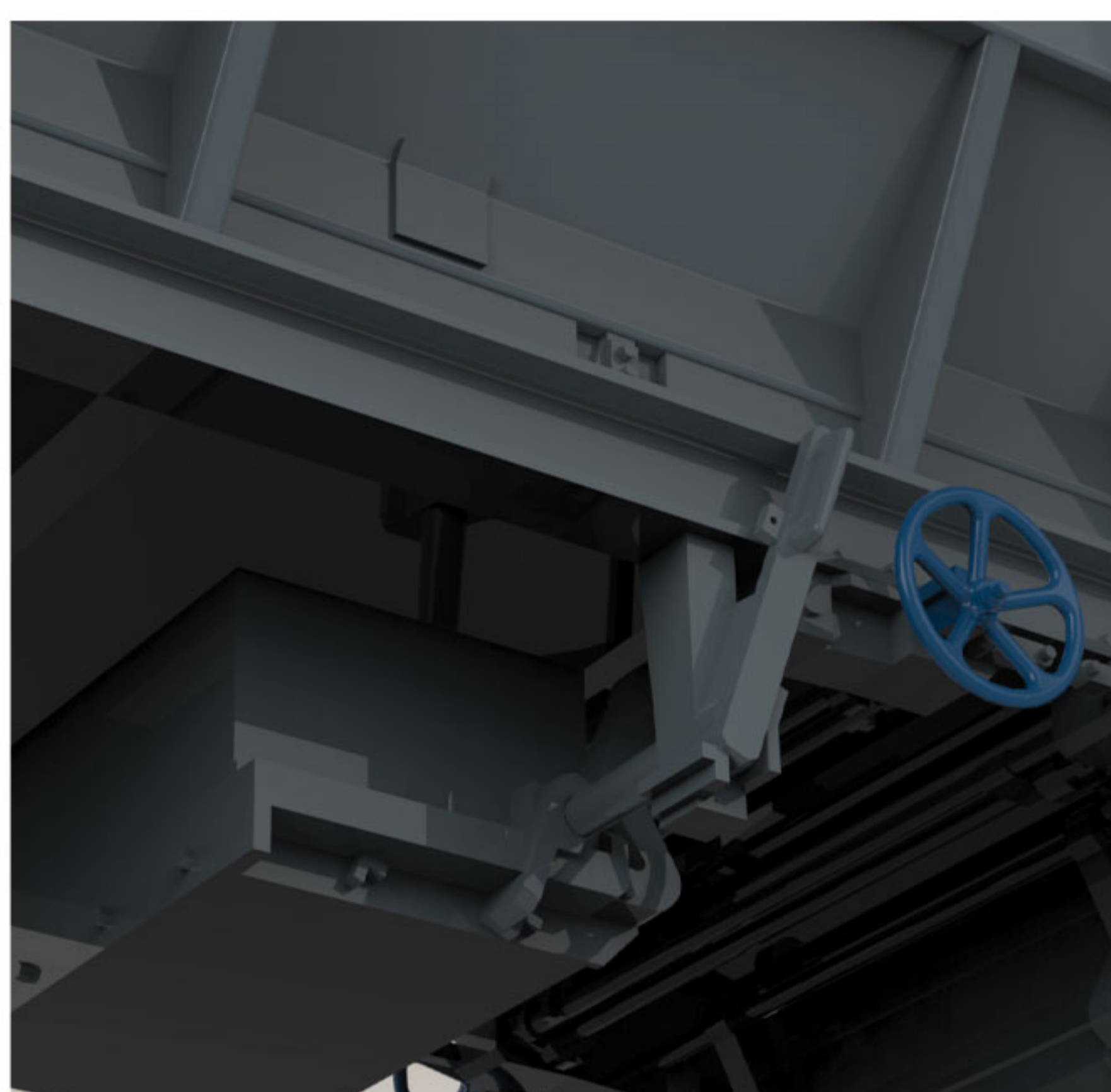
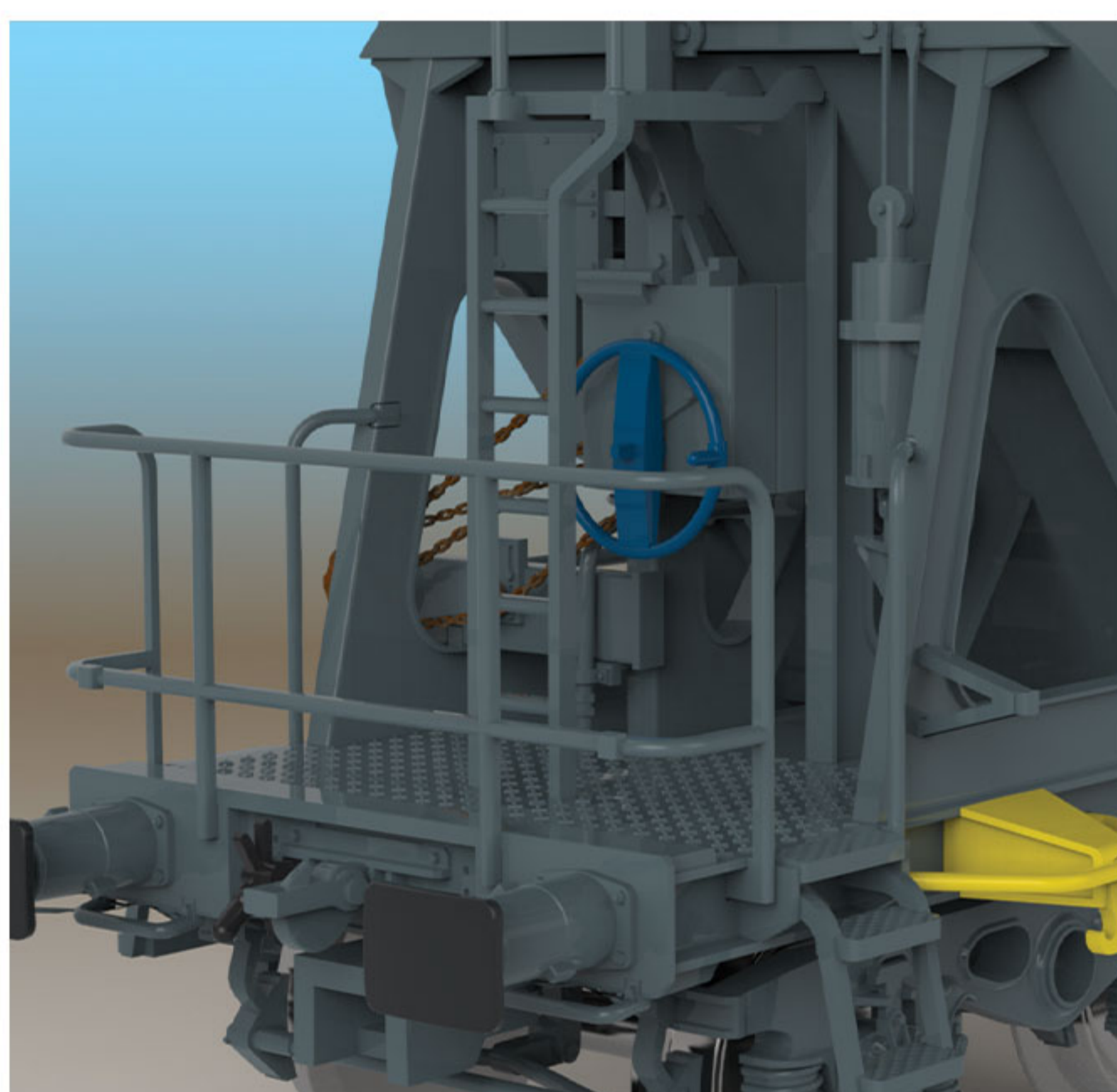
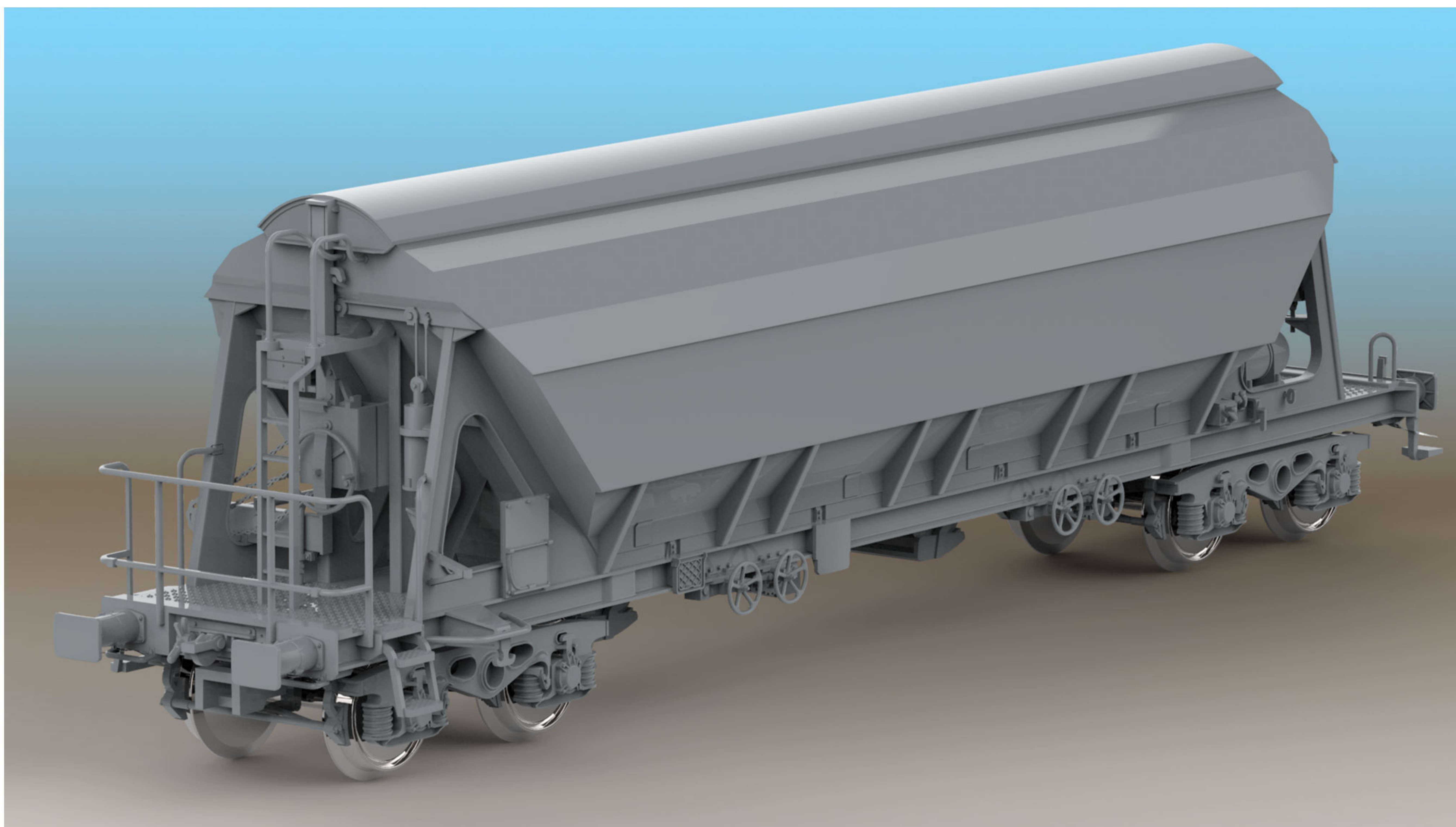

SNCF - "Sucre" Tapps freight wagon

France

Era: V

Registration number : 33 87 0658 603-3

Albert Modell 065301

2-rail



HO (1:87) | 182 mm | 358 mm | NEM 362

SNCF - "Sucre" Tapps freight wagon

France

Era: V

Registration number : 33 87 0658 618-1

Albert Modell 065302

2-rail



HO (1:87) | 182 mm | 358 mm | NEM 362

ERMEWA - "Sucre" Tapps freight wagon

France

Era: VI

Registration number : 33 87 0658 701-5

Albert Modell 065303

2-rail



HO (1:87) | 182 mm | 358 mm | NEM 362

ERMEWA - "Sucre" Tapps freight wagon

France

Era: VI

Registration number : 33 87 0658 653-8

Albert Modell 065304

2-rail



HO (1:87) | 182 mm | 358 mm | NEM 362

SNCF - T84 Tapps freight wagon

France

Era: V

Registration number : 31 87 0658 016-0

Albert Modell 065305

2-rail

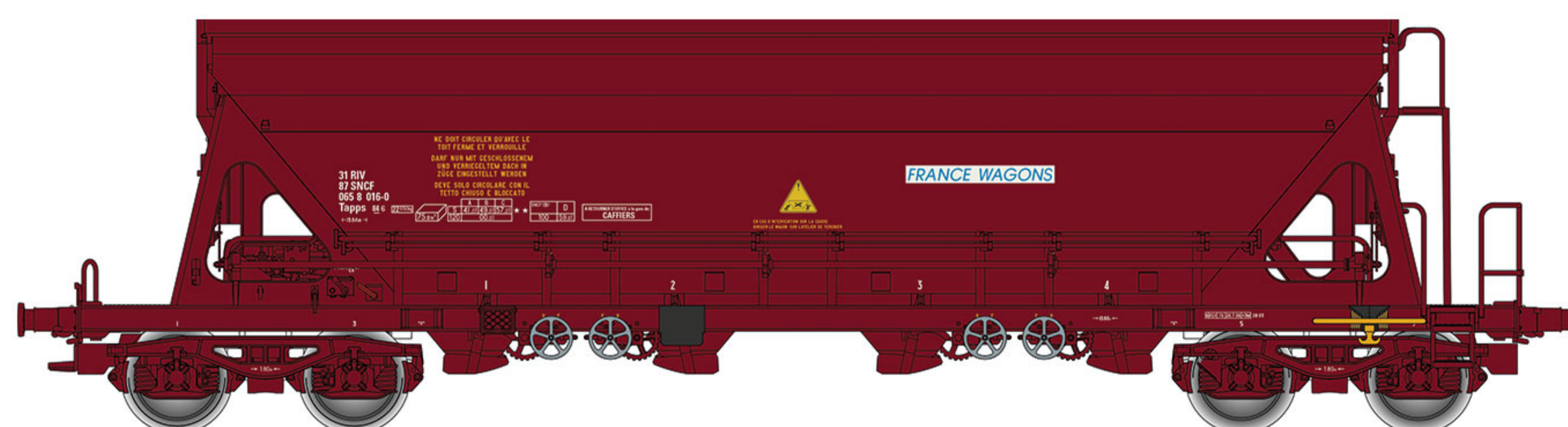

HO (1:87) | 182 mm | 358 mm | NEM 362

SNCF - T84 Tapps freight wagon

France

Era: V

Registration number : 31 87 0658 033-5

Albert Modell 065306

2-rail

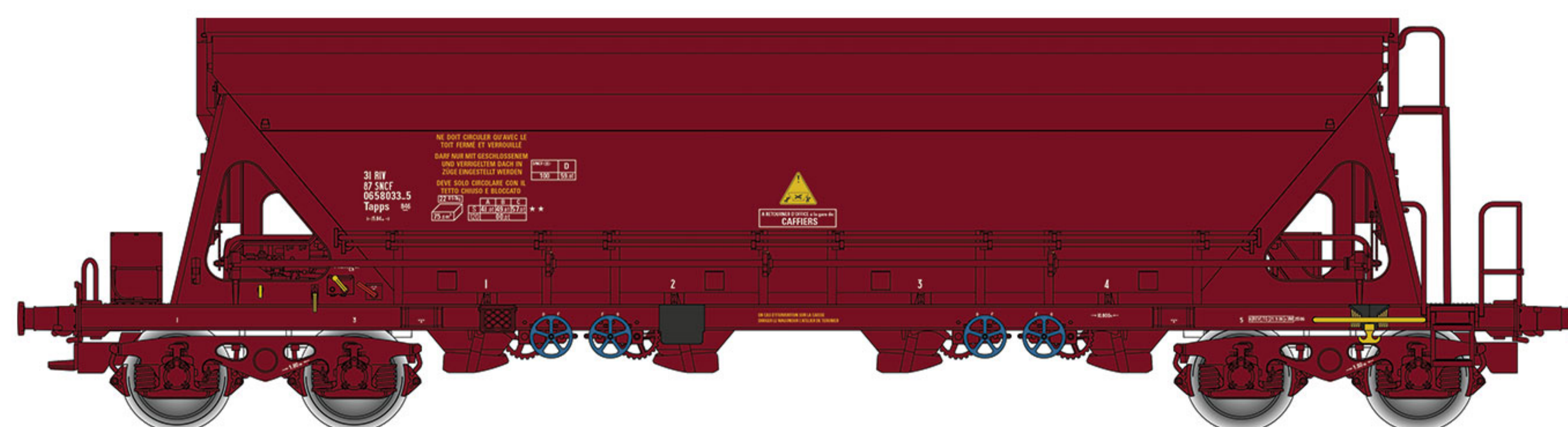

HO (1:87) | 182 mm | 358 mm | NEM 362

ERMEWA - T84 Tapps freight wagon

France

Era: VI

Registration number : 33 87 0658 278-4

Albert Modell 065307

2-rail

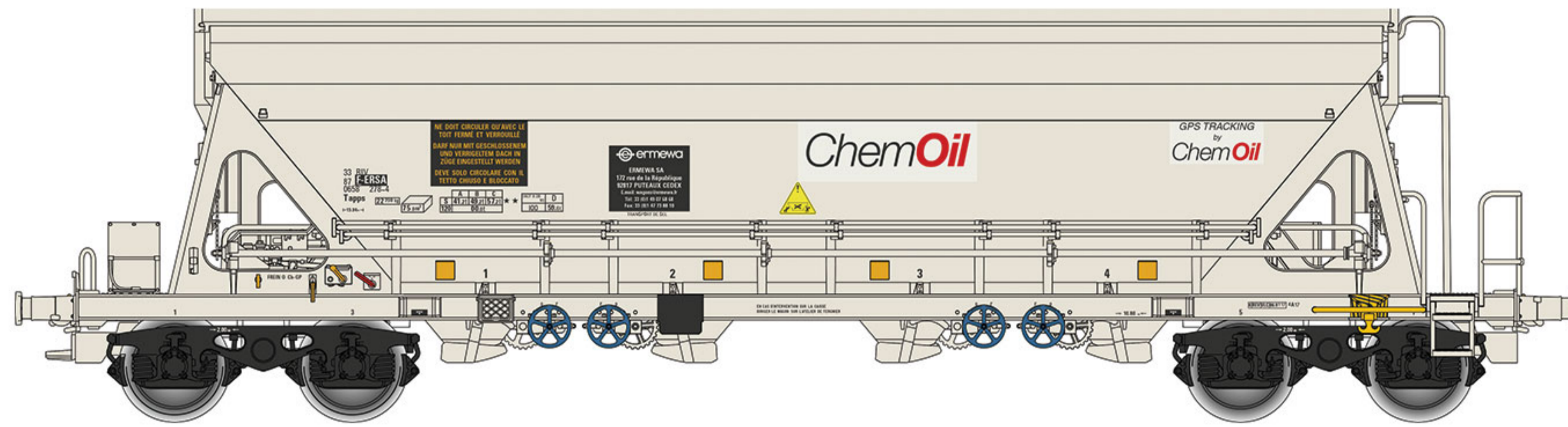

HO (1:87) | 182 mm | 358 mm | NEM 362

ERMEWA - T84 Tapps freight wagon

France

Era: VI

Registration number : 33 87 0658 231-3

Albert Modell 065308

2-rail

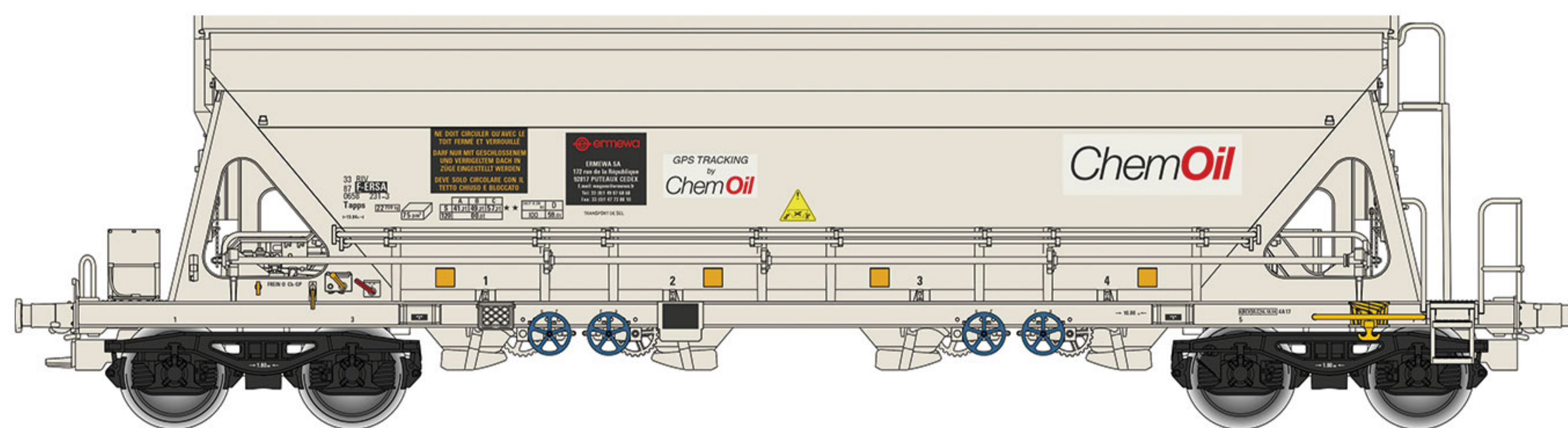

HO (1:87) | 182 mm | 358 mm | NEM 362

ERMEWA - T90 Tanpps freight wagon

France

Era: VI

Registration number : 33 87 0659 087-8

Albert Modell 065309

2-rail



HO (1:87) | 182 mm | 358 mm | NEM 362

ERMEWA - T90 Tanpps freight wagon

 France

Era: VI

Registration number : 33 87 0659 220-5

Albert Modell 065310

 2-rail



 HO (1:87) |  182 mm |  358 mm |  NEM 362

SNCF - T90 Tanpps freight wagon

 France

Era: IV

Registration number : 31 87 5659 399-8

Albert Modell 565001

 2-rail



 HO (1:87) |  182 mm |  358 mm |  NEM 362

SNCF - T90 Tanpps freight wagon

 France

Era: IV

Registration number : 31 87 5659 446-7

Albert Modell 565002

 2-rail



 HO (1:87) |  182 mm |  358 mm |  NEM 362

ALBERT MODELL

About us

The history of our company

Established in 2014, Albert-Modell has swiftly emerged as a known name in the world of model railway manufacturing. Our international presence, which commenced in 2017, marks a significant milestone in our journey. At Albert-Modell, our primary focus rests on producing exquisitely detailed models of Eastern European freight wagons, alongside an impressive range of diesel locomotives, but our range includes more and more models from countries like Germany and Switzerland.

Our philosophy is anchored in the belief that model-making is an art that demands precision, detail, and affordability. We strive to blend these elements, offering our clients high-quality, intricately designed models at a price that respects their passion and investment in this hobby.

Our products are crafted not merely as toys, but as collectibles, with a dedication to craftsmanship.

We pride ourselves on producing models in limited quantities, ensuring that each piece we create is not just a model but an elegant representation of the original. This approach underlines our commitment to quality over quantity, making our models sought-after items for collectors and enthusiasts who value exclusivity and authenticity.

À propos de nous

L'histoire de notre entreprise

Fondée en 2014, Albert-Modell s'est rapidement imposée comme un nom reconnu dans le monde de la fabrication de trains miniatures. Notre présence internationale, commencée en 2017, marque une étape importante dans notre parcours. Chez Albert-Modell, notre objectif principal est de produire des modèles extrêmement détaillés de wagons de marchandises d'Europe de l'Est, ainsi qu'une gamme impressionnante de locomotives diesel, mais notre gamme inclut de plus en plus de modèles de pays comme l'Allemagne et la Suisse.

Notre philosophie repose sur la conviction que la modélisation est un art qui exige précision, détail et accessibilité. Nous nous efforçons de combiner ces éléments, offrant à nos clients des modèles de haute qualité, finement conçus, à un prix qui respecte leur passion et leur investissement dans ce loisir. Nos produits ne sont pas simplement des jouets, mais des objets de collection, avec un dévouement à l'artisanat.

Nous sommes fiers de produire des modèles en quantités limitées, garantissant que chaque pièce que nous créons n'est pas seulement un modèle, mais une représentation élégante de l'original. Cette approche souligne notre engagement envers la qualité plutôt que la quantité, faisant de nos modèles des objets recherchés par les collectionneurs et les passionnés qui apprécient l'exclusivité et l'authenticité.

TD TrainsDepot.org

We highlight your miniatures

© 2024 TrainsDepot.org - All right reserved

Felvidéki u. 8, Komárom,
H-2900 - Ungarn

info.albertmodell@gmail.com
www.albertmodell.com